

Technical Charts

Model	LI 700	LI 670	LI 670	LI 640	LL 65	LL 64	L 63
Design	Experience	Experience	Elegance	Elegance	Premiere	Premiere	Premiere
Colors	Stainless Steel Integrated	Stainless Steel	White/Black	White/Black/Integrated Stainless Steel	Stainless Steel (Finger Print Free)	White/Black Stainless Steel (Finger Print Free)	White/Black Stainless Steel (Finger Print Free)
Special Features							
Energy Star	▪	▪	▪	▪	▪	▪	▪
True Care System (Automatic Water Softener)	▪	▪	▪	▪	▪	▪	▪
Super Dry (Turbo Fan)	▪	▪	▪	▪	▪	▪	▪
Extra Dry Option	▪	▪	▪	▪	▪	▪	▪
Silence level	49 dBA	51 dBA	51 dBA	53 dBA	49 dBA	51 dBA	53 dBA
Concealed Heating Element (Flow Through Heat Exchanger)	▪	▪	▪	▪	▪	▪	▪
MultiSystem Racks	▪	▪	▪	▪	▪	▪	▪
Sensor System	▪	▪	▪	▪	▪	▪	▪
Delay Timer (h)	2/4/6				3/6/9/12		
Half Load (Upper Rack)	▪				▪		
Main Features							
Wash Programs & Options	7+3 options	7+1 option	7+1 option	4+1 option	6+2 options	6	5
Intensive Wash					▪	▪	▪
Super Wash	Auto	Auto	Auto				
Regular Wash	Auto	Auto	Auto				
Eco-Wash	Auto	Auto	Auto				
Rapid Wash	▪	▪	▪				
Crystal Care Wash	▪	▪	▪				
Pots Plus Wash	Auto	Auto	Auto				
Soak	▪	▪	▪				
Washing Temperatures	up to 160°F	up to 160°F	up to 160°F	up to 160°F	up to 156°F	up to 156°F	up to 156°F
Wash Levels	4	4	4	4	4	4	4
Drying System	Super Dry	Dynamic Drying	Dynamic Drying	Dynamic Drying	Super Dry	Dynamic Drying	Dynamic Drying
No. of Place Settings	12	12	12	12	12	12	12
Primary Functions and Display Commands							
Control Interface / Programs	Electronic Push Button	Electronic Push Button	Electronic Push Button	Electronic Push Button	Electronic Push Button	Electronic Push Button	Electronic Dial
On/Off button	▪	▪	▪	▪	▪	▪	▪
Start/Reset button	▪	▪	▪	▪	▪	▪	▪
Extra Dry button	▪	▪	▪	▪	▪	▪	▪
Rinse Aid Refill light	▪	▪	▪	▪	▪	▪	▪
Salt Refill light	▪	▪	▪	▪	▪	▪	▪
Program Indicator LED	▪	▪	▪	▪	▪	▪	▪
Wash sequence LED	▪	▪	▪	▪	▪	▪	▪
Cancel Drain Option	▪	▪	▪	▪	▪	▪	▪
Product Structure							
2 Pump and Motor System	▪	▪	▪	▪	▪	▪	▪
Stainless Steel Tub and Inner Door	▪	▪	▪	▪	▪	▪	▪
4 Piece Stainless Steel Filter	▪	▪	▪	▪	▪	▪	▪
Adjustable Rinse Aid Dispenser	▪	▪	▪	▪	▪	▪	▪
MultiSystem Racks & Cutlery Basket	III	II	I	I	III	II	I
Nylon coated colors	Platinum	Platinum	Platinum	White	Platinum	Platinum	White
Adjustable / Removable Upper Rack	Click-Clack / ▪	Click-Clack / ▪	Click-Clack / ▪	▪ / ▪	Click-Clack / ▪	Click-Clack / ▪	▪ / ▪
Detergent dispenser with pre-wash compartment	▪	▪	▪	▪	▪	▪	▪
3 Piece MultiSystem Cutlery Basket	▪	▪	▪	▪	▪	▪	▪
True Care Cutlery Basket Divider	▪	▪	▪	▪	▪	▪	▪
Full Exterior Side Panels	▪	▪	▪	▪	▪	▪	▪
Enclosed Bottom Pan	▪	▪	▪	▪	▪	▪	▪
Voltage/Frequency/Amps	120 V / 60 Hz / 15 Amps	120 V / 60 Hz / 15 Amps	120 V / 60 Hz / 15 Amps	120 V / 60 Hz / 15 Amps	120 V / 60 Hz / 15 Amps	120 V / 60 Hz / 15 Amps	120 V / 60 Hz / 15 Amps
Product Weight Packaged	98 (lbs) / 44.5 (kg)	98 (lbs) / 44.5 (kg)	98 (lbs) / 44.5 (kg)	98 (lbs) / 44.5 (kg)	105 (lbs) / 47.5 (kg)	105 (lbs) / 47.5 (kg)	105 (lbs) / 47.5 (kg)
Product Weight Un-Packaged	91 (lbs) / 41.2 (kg)	91 (lbs) / 41.2 (kg)	91 (lbs) / 41.2 (kg)	91 (lbs) / 41.2 (kg)	98 (lbs) / 44.4 (kg)	98 (lbs) / 44.4 (kg)	98 (lbs) / 44.4 (kg)
Safety							
Bottom Pan Floater Switch	▪	▪	▪	▪	▪	▪	▪
Flow Meter	▪	▪	▪	▪	▪	▪	▪
Water Stop (dual valve system)	▪	▪	▪	▪	▪	▪	▪
Dimensions/Installation							
Fast Fix Installation System	▪	▪	▪	▪	▪	▪	▪
Flexible Side Filler Strips (brings unit to 24")	▪	▪	▪	▪	▪	▪	▪
2" Extension Panel (removable for European Cabinet Installation)	▪ (except I model)	▪	▪	▪ (except I model)	▪	▪	▪
Adjustable Toe Kick	▪	▪	▪	▪	▪	▪	▪
Accepts 3/4" Custom Panels	▪	▪	▪	▪	▪	▪	▪
Height	32.25"-34.5" / 82-87.5 cm	32.25"-34.5" / 82-87.5 cm	32.25"-34.5" / 82-87.5 cm	32.25"-34.5" / 82-87.5 cm	32.25"-34.5" / 82-87.5 cm	32.25"-34.5" / 82-87.5 cm	32.25"-34.5" / 82-87.5 cm
Width (without filler strips)	23.4" / 59.5 cm	23.4" / 59.5 cm	23.4" / 59.5 cm	23.4" / 59.5 cm	23.6" / 60 cm	23.6" / 60 cm	23.6" / 60 cm
Depth	23.2" / 59 cm	23.2" / 59 cm	23.2" / 59 cm	23.2" / 59 cm	23.6" / 60 cm	23.6" / 60 cm	23.6" / 60 cm

Ariston reserves the right to bring changes to the products specification without notice
UL and CUL listed.

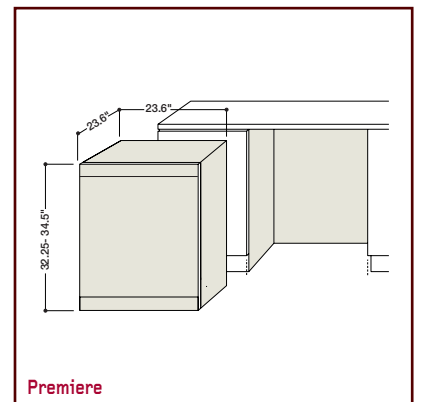
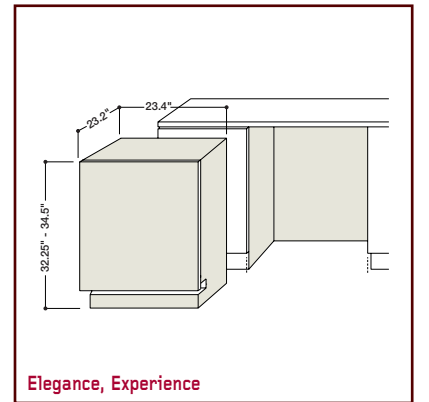

For planning only, for details see product manuals

MultiSystem Rack and Cutlery Basket

	Upper	Lower	Cutlery Basket	Cup shelves	Color
III	Design handle + Click Clack	Design handle 2 flip tines	3 piece with cover	2	Platinum
II	Click Clack	2 flip tines	1 piece with cover	2	Platinum
I	Manual Adjustment	2 flip tines	1 piece with cover	1	White

Warranty: 2 years parts & labor, 5 years on all electronic components (parts only), 5 years on rack (parts only), lifetime warranty against rust-through on stainless steel tub and door.
(Certain limitations apply, see manufactures limited warranty details).